



# IR Gas Filter Correlation Carbon Monoxide Analyzer **CO12M**



**NEW: on board web server and es@cloud™** user interface with on-line help for the display, configuration, maintenance, diagnostics or software updating of the analyser, remotely, from any PC, tablet or iPhone.



es@cloud™

TCP/IP remote control with dynamic, multilingual interface, featuring intuitive navigation by pictograms.



Example of mobile air quality monitoring station with rack version 2M series analyzers.

## EXCLUSIVE FEATURES:

- GFC analyzer designed for high sensitivity monitoring of low CO concentrations in the range of 40 ppb-200 ppm
- User programmable ranges and average times; auto-ranging
- Automatic pressure compensation
- Sealed gas cells
- Real time calibration graph
- Full remote emulation of the analyzer
- Graphic Liquid Crystal (LCD) display
- Built-in USB port and serial interface (RS 232 / RS 422), Ethernet connection for full remote control and display functions
- Extremely compact, easy to use
- Built-in storage of 12 months 1/4 h average data
- Includes embedded Communication Protocol for XR® Management Software
- Interactive menu-driven display allowing user-friendly and intuitive interface for the operator
- *Options:* CO<sub>2</sub> (max 3000 ppm) / CH<sub>4</sub> (max 300 ppm) measurement
- Compliance with **ISO 4224** and **EN 14626** standards

## Type approvals:

- > TÜV report n° 936/21206773/B (Germany),
- > US EPA n°RFCA-0206-147 (USA)

## APPLICATIONS:

Continuous indoor and outdoor air quality monitoring • Stationary and mobile AQMS laboratories • Industrial fence-line monitoring • Continuous emissions monitoring (CEM) by dilution • Measurement Campaigns and Monitoring Studies • Impurities in industrial gases...



# IR Gas Filter Correlation Carbon Monoxide Analyzer **CO12M**

## SPECIFICATIONS:

- Ranges: 0-10/ 25 / 50 /100 / 200 ppm or user selectable ranges
- Autoranging between two-user specified ranges
- Noise: 20 ppb
- Lower detectable limit (2σ): 40 ppb
- Response time: automatic and programmable (minimum 30 sec)
- Zero drift: less than 0.5 ppm / 24 h and less than 0.1 ppm / 7 days
- Span drift: less than 0.5% / 24 h and less than 1% / 7 days
- Interference rejection ratio:
  - H<sub>2</sub>O: less than 1/200 000
  - CO<sub>2</sub>: less than 1/70 000
- Linearity: ± 1 % of F.S.
- Pressure and temperature compensation
- Internal sample pump
- Sample flow rate: 1 lpm
- Averaging time: programmable from 1 min. to 24h
- Data storage: 12 months (1/4h data)
- Chassis: 19" rack, 3U
- Dimensions: (L x W x H): 483 x 545 x 133 mm
- Weight: 8 kg (17.6 lbs)
- Power supply: 115 V, 60 Hz / 230 V, 50/60 Hz
- Power consumption: 50 VA
- Operating temperature: +5 to +40°C (typical as per US EPA 10 - 35° C)
- Ethernet connection, USB port and serial interface (RS 232 / RS 422)
- PVDF sample filter holder
- Valves block for selection of customer supplied zero and span gas

## OPTIONS:

- Ethernet network connection
- ESTEL electronic board (1 or 2) with:
  - 4 independent analog inputs
  - 4 independent analog outputs
  - 4 remote control inputs
  - 6 dry contacts outputs
- SOREL electronic board with:
  - 4 dry contacts outputs
  - 4 dry contacts inputs
- CO<sub>2</sub> (max 3000 ppm) / CH<sub>4</sub> (max 300 ppm) measurement
- 24V DC power supply for on-board applications
- Tight box version
- 7" color touch screen upon request

## OPERATING PRINCIPLE:

The NDIR GFC (Non Dispersive InfraRed Gas Filter Correlation) carbon monoxide analyzer CO12M, combines over 25 years of experience in the NDIR CO measurement with an enhanced electronics package and a modular component parts design.

The outcome is an ultra compact and light – rack 3U, easy-to-use, IR-GFC based analyzer able to measure carbon monoxide with an excellent stability and accuracy.

The CO sample concentration is determined by measuring the quantity of infrared light the sample gas absorbs as it flows through a multi-cell correlation wheel filled on one side with a reference CO cell (reference beam) and on the other side with an empty cell (the measurement beam). As the wheel turns round, the light beam passes alternatively through the CO cell and the empty cell and then through an interference optical filter before reaching the optical detector. If the sample contains CO, the reference beam will not be attenuated by it because it was already attenuated by the CO of the reference cell.

The analyzer was developed to meet customers' requirement for reduced and easier maintenance. Equipped with sealed gas cells located in the air tight thermoregulated measurement module, the CO12M combines a powerful, easy-to-use interface with state-of-the-art components and design technology.

Real-time calibration graphs can be displayed during span check operation. Multitasking software allows advanced calculation such as wind direction averaging and gives a user-friendly access to the instrument set-up, as well as the status and maintenance parameters. Real-time synoptic, auto-diagnostic and maintenance data screens can be displayed while the instrument is operating.

As the entire 2M series, the CO12M analyzer integrates an embedded web server featuring intuitive navigation by pictograms and offering quick and easy access to the analyzer, without the use of a special software. Secured, modern, simple, fast and accessible from any type of browser, the es@cloud™ interface allows the display, configuration, maintenance, diagnostics or software updating of Environnement SA analyzers, remotely, from any PC, tablet or SmartPhone.

From customising menus with shortcut key functions, "favourite" themes and animated diagrams, everything has been designed for a quick familiarisation and a comfortable use of the analyzers: just *plug and play!*

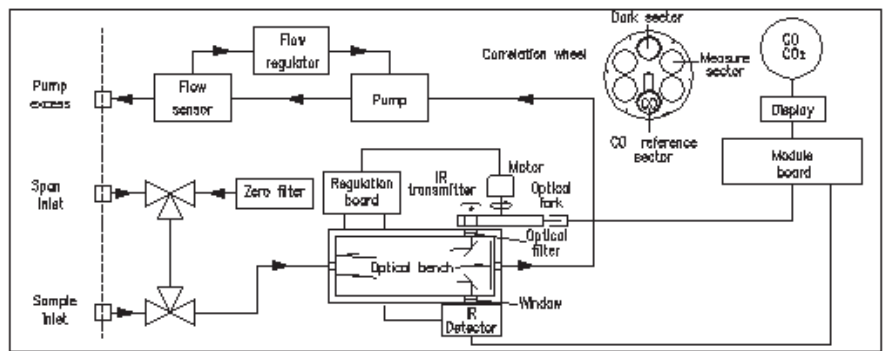

Distributed by:



Typical specifications subject to changes without prior notice.